

USER MANUAL

MOVITEC WL-250

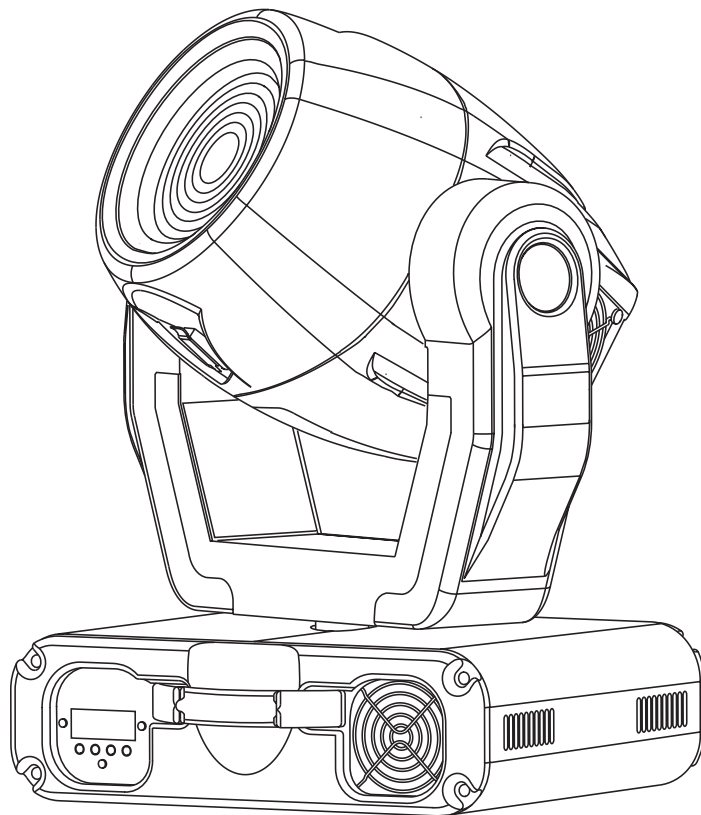

MOVITEC WL-250

Table of contents

1. Safety	3
1.1 Safety instructions.....	3
1.2 Operating determinations.....	4
2. Introduction	5
2.1 Features	5
2.2 Beampath.....	5
2.3 Description of device.....	6
3. Installation	7
3.1 Fitting the lamp	7
3.2 Rigging the fixture	8
3.3 Connection to the mains	9
3.4 DMX-512 connection/connection between fixtures	9
4. DMX-Protocol	10
4.1 Function of the control channels - 16 bit protocol	10
4.2 Function of the control channels - 8 bit protocol	12
5. Addressing	12
6. Remotely controllable functions	13
6.1 Lamp	13
6.2 Switching On and Off the lamp by Control Board	13
6.3 Colour wheel	13
6.4 CMY - colours mixing system.....	13
6.5 Beam effects	13
6.6 Dimmer	13
6.7 Shutter/Strobe	13
6.8 Fan.....	13
7. Control Board	14
7.1 Main functions	14
7.2 SPEC -Special functions	15
8. Error and information messages	18
9. Technical specifications	19
10. Maintenance and cleaning	20
11. Appendix	21



CAUTION!
Keep this device away from rain and moisture!
Unplug mains lead before opening the housing!



**FOR YOUR OWN SAFETY, PLEASE READ THIS USER MANUAL CAREFULLY
BEFORE YOU INITIAL START - UP!**

1. Safety

1.1 Safety instructions

Every person involved with installation and maintenance of this device have to:

- be qualified
- follow the instructions of this manual



Caution ! Be careful with your operations.
With a voltage of 230V you can suffer
a dangerous electric shock when touching the wires!



This device has left our premises in absolutely perfect condition. In order to maintain this condition and to ensure a safe operation, it is absolutely necessary for the user to follow the safety instructions and warning notes written in this manual.

Important:

The manufacturer will not accept liability for any resulting damages caused by the non-observance of this manual or any unauthorized modification to the device.

Please consider that damages caused by manual modifications to the device are not subject to warranty.

Never let the power-cord come into contact with other cables! Handle the power-cord and all connections with the mains with particular caution!

Make sure that the available voltage is not higher than stated on the rear panel.

Always plug in the power plug least. Make sure that the power-switch is set to OFF-position before you connect the device to the mains. The power-plug has to be accessible after installing the device.

Make sure that the power-cord is never crimped or damaged by sharp edges. Check the device and the power-cord from time to time.

Always disconnect from the mains, when the device is not in use or before cleaning it. Only handle the power-cord by the plug. Never pull out the plug by tugging the power-cord.

This device falls under protection class I. Therefore it is essential to connect the yellow/green conductor to earth.

The electric connection, repairs and servicing must be carried out by a qualified employee.

Do not connect this device to a dimmer pack.

Do not switch the fixture on and off in short intervals as this would reduce the lamp's life.

During the initial start-up some smoke or smell may arise. This is a normal process and does not necessarily mean that the device is defective.

Do not touch the device's housing bare-handed during its operation (housing becomes hot)!
For replacement use lamps and fuses of same type and rating only.



CAUTION ! EYEDAMAGES !
Avoid looking directly into the light source
(meant especially for epileptics) !



1.2 Operating determinations

This device is a moving-head spot for creating decorative effects. This product is only allowed to be operated with an alternating current of 230 V, 50 Hz and was designed for indoor use only.

If the device has been exposed to drastic temperature fluctuation (e.g. after transportation), do not switch it on immediately. The arising condensation water might damage your device. Leave the device switched off until it has reached room temperature.

Never run the device without lamp!

Do not shake the device. Avoid brute force when installing or operating the device.

Never lift the fixture by holding it at the projector-head, as the mechanics may be damaged. Always hold the fixture at the transport handles.

When choosing the installation-spot, please make sure that the device is not exposed to extreme heat, moisture or dust. There should not be any cables lying around. You endanger your own and the safety of others!

The minimum distance between light-output and the illuminated surface must be more than 1 meter.

Make sure that the area below the installation place is blocked when rigging, derigging or servicing the fixture.

Always fix the fixture with an appropriate safety-rope. Fix the safety-rope at the correct holes only.

Only operate the fixture after having checked that the housing is firmly closed and all screws are tightly fastened.

The lamp must never be ignited if the objective-lens or any housing-cover is open, as discharge lamps may explode and emit a high ultraviolet radiation, which may cause burns.

The maximum ambient temperature $t_a = 45^\circ \text{C}$ must never be exceeded. Otherwise, the lamp is switched off and the fixture is out of operation for 5 minutes.



CAUTION!

The lens has to be replaced when it is obviously damaged, so that its function is impaired, e. g. due to cracks or deep scratches!

Operate the device only after having familiarized with its functions. Do not permit operation by persons not qualified for operating the device. Most damages are the result of unprofessional operation!



CAUTION!

The lamp has to be replaced when it is damaged or deformed due to the heat!

Please use the original packaging if the device is to be transported.

Please consider that unauthorized modifications on the device are forbidden due to safety reasons!

If this device will be operated in any way different to the one described in this manual, the product may suffer damages and the guarantee becomes void. Furthermore, any other operation may lead to dangers like short-circuit, burns, electric shock, burns due to ultraviolet radiation, lamp explosion, crash etc.

2. Introduction

Unpack your MOVITEC WL-250 and make sure that there are no damages caused by transportation. Should there be any, please consult your local dealer and do not take the device into operation.

2.1 Features

Moving-head spot with washlight

CMY colour mixture • Motorised colour wheel with additional 6 discrete dichroic filters plus open • Colours: red, green, blue, 3200 K and 5600 K corrections filters, black-light (UV) • Colour-wheel continuous rotation (rainbow effect) in both directions • Shutter unit allowing very fast blackout function and strobo effect 1-10 flash per sec. • Dimmer unit very smooth dimming • Wide and flat beam can steplessly be rotated by 90° • Frost filter for softer beam • Manually adjustable beam angle from 8° to 22° • Modular construction of fixture • Addressing, special functions setting, effects calibration via control panel with 4-digit LED display • Readout fixture and lamp usage, receiving DMX values, temperature, etc • Built-in analyzer for easy fault finding, error messages • Remotely switching of the lamp • Built-in demo sequences • Preprogrammed variable/random strobe and dimmer pulse-effects • Macro-function for CMY colour combinations • Black-out while Head moving or colour changing • Remotely controllable speed of Pan/Tilt movement for easy programming • Remote reset function • Intelligent control panel with 4-digit LED display • Silent fans cooling; remotely controllable speed of fans • 16 DMX-channels - 16 bit Pan/Tilt movement resolution • 14 DMX-channels - 8 bit Pan/Tilt movement resolution • Pan-movement range 530° • Tilt-movement range 280° • 8/16 bit movement resolution • Automatic Pan/Tilt position correction • High luminous-efficiency parabolic reflector • Fresnel lens of diameter 150 mm • 9 high-quality stepper-motors for smooth movements • Self-resettable thermo-fuse • For MSD/HSD 230 V/250 W GY-9.5 or MSD/HSD 230 V/200 W GY-9.5 lamp • DMX-control via every standard DMX-controller •

2.2 Beampath

Min. beam angle 8°

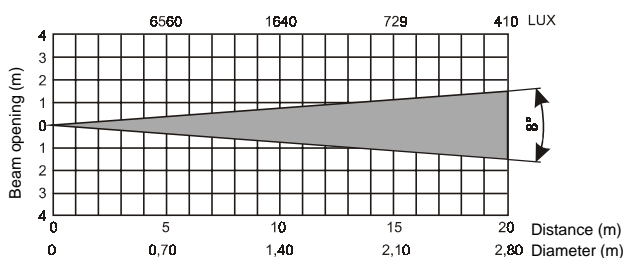

Max. beam angle 22°

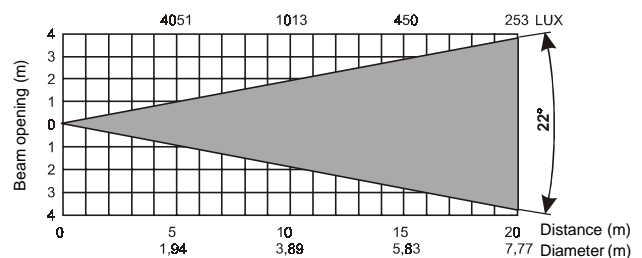

2.3 Description of device

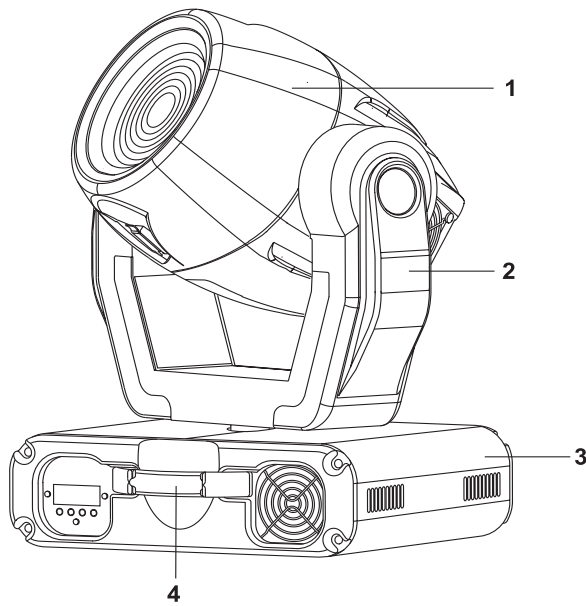

- 1 - Moving Head
- 2 - Yoke
- 3 - Base
- 4 - Carrying handles

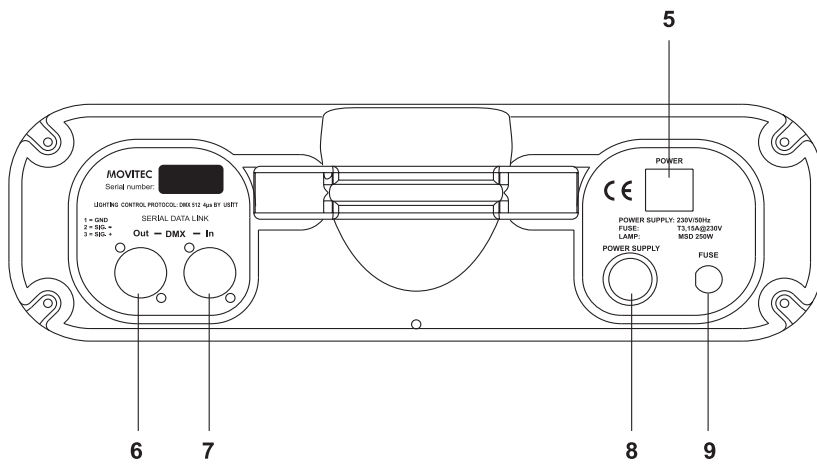

- Rear panel:**
- 5 - Power-switch
 - 6 - DMX output
 - 7 - DMX input
 - 8 - Powercord
 - 9 - Fuseholder

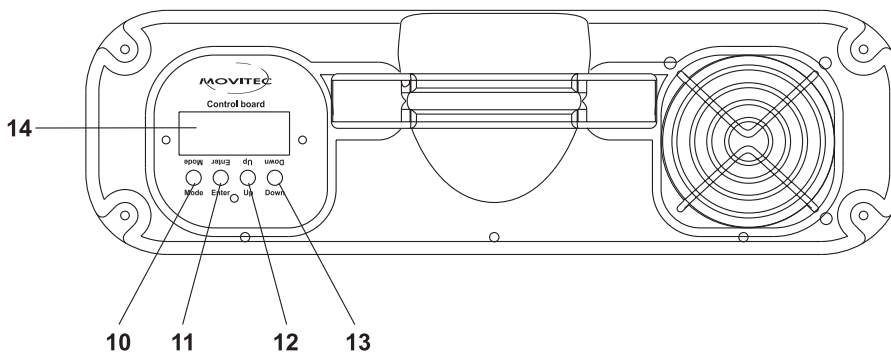

- Front panel:**
- 10 - Mode-button
 - 11 - Enter-button
 - 12 - Up-button
 - 13 - Down-button
 - 14 - Display

3. Installation

3.1 Fitting the lamp



DANGER !
Install the lamps with the device switched off only.
Unplug from mains before !



To insert the lamp MSD 230V/250W or MSD 230V/200W open the small cover at the rear of head (See the drawings) by loosening the 2 Phillips screws on the cover.

Gently pull out the lamp assembly.

If changing the lamp, remove the old lamp from the socket. Insert the lamp to the socket.

Do not install a lamp with a higher wattage! A lamp like this generates temperatures the device is not designed for.

Damages caused by non-observance are not subject to warranty. Please follow the lamp manufacturer's notes! Do not touch the glass-bulb bare-handed during the installation! Make sure that the lamp is installed tightly into the lampholder system.

Reinsert the lamp assembly and tighten 2 screws again.

Before striking the lamp, reset the "LAti" counter in the main menu of the Control Board, by pressing the "Up" and "Down" buttons in one time and then confirming with the **Enter**-button.

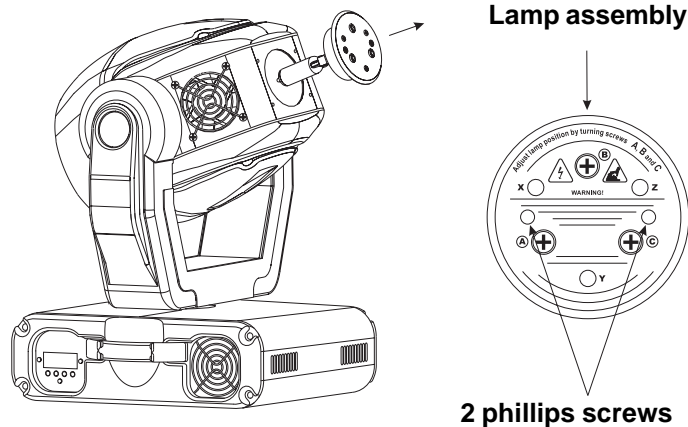

Do not operate this fixture with opened housing-cover!

Lamp adjustment of MOVITEC WL-250

The MOVITEC WL-250 lampholder is aligned at the factory. Due to differences between lamps, fine adjustment may improve light performance.

Strike the lamp and focus the light on a flat surface (wall).

Center the hot-spot (the brightest part of the beam) using the 3 adjustment screws „A, B, C”. Turn one screw at a time to drag the hot-spot, diagonally across the projected image. If you cannot detect a hot-spot, adjust the lamp until the light is even.

To reduce a hot-spot, pull the lamp in by turning all three screws „A, B, C” clockwise 1/4-turn at a time until the light is evenly distributed.

If the light is brighter around the edge than it is in the center, or if light output is low, the lamp is too far back in the reflector. „Push” the lamp out by turning the screws „A, B, C” counterclockwise 1/4-turn at a time the light is bright and evenly distributed.

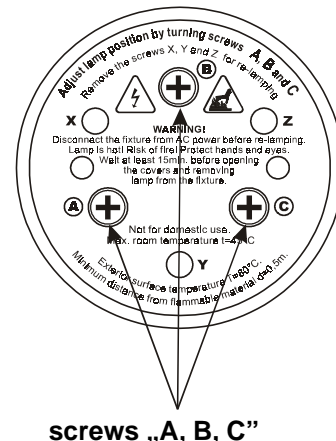

screws „A, B, C”

3.2 Rigging the fixture



Danger of fire !
When installing the device, make sure there is no highly inflammable material (decoration articles, etc.) in between a distance of min. 0,5 m.



Warning ! Use 2 clamps to rig the fixture on the truss.
Follow the instructions mentioned at the bottom of the base.
Make sure that the device is fixed properly! Ensure that the structure (truss) to which you are attaching the fixtures is secure.



The WL-250 can be placed directly on the stage floor or rigged in any orientation on a truss without altering its operation characteristics (see the drawing). The fixture's base enables to be mounted in two ways. Use the clamps with screws M10.

Install a safety wire that can hold at least 10 times the weight of the fixture. Never use the carrying handles for secondary attachment.

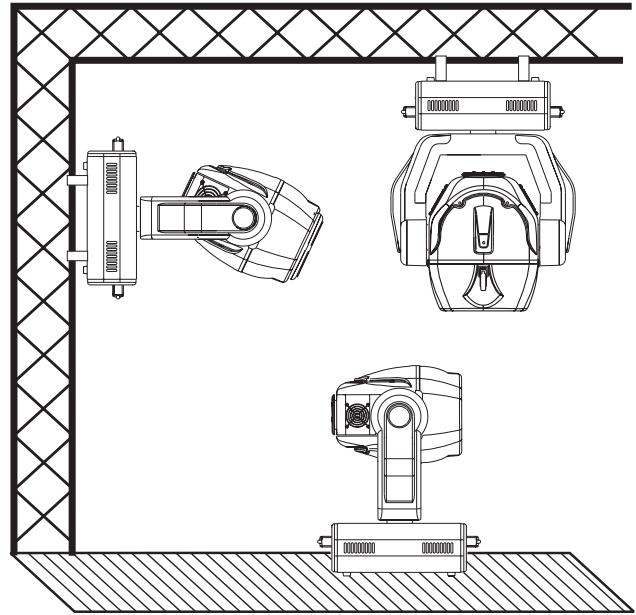

Secure chain

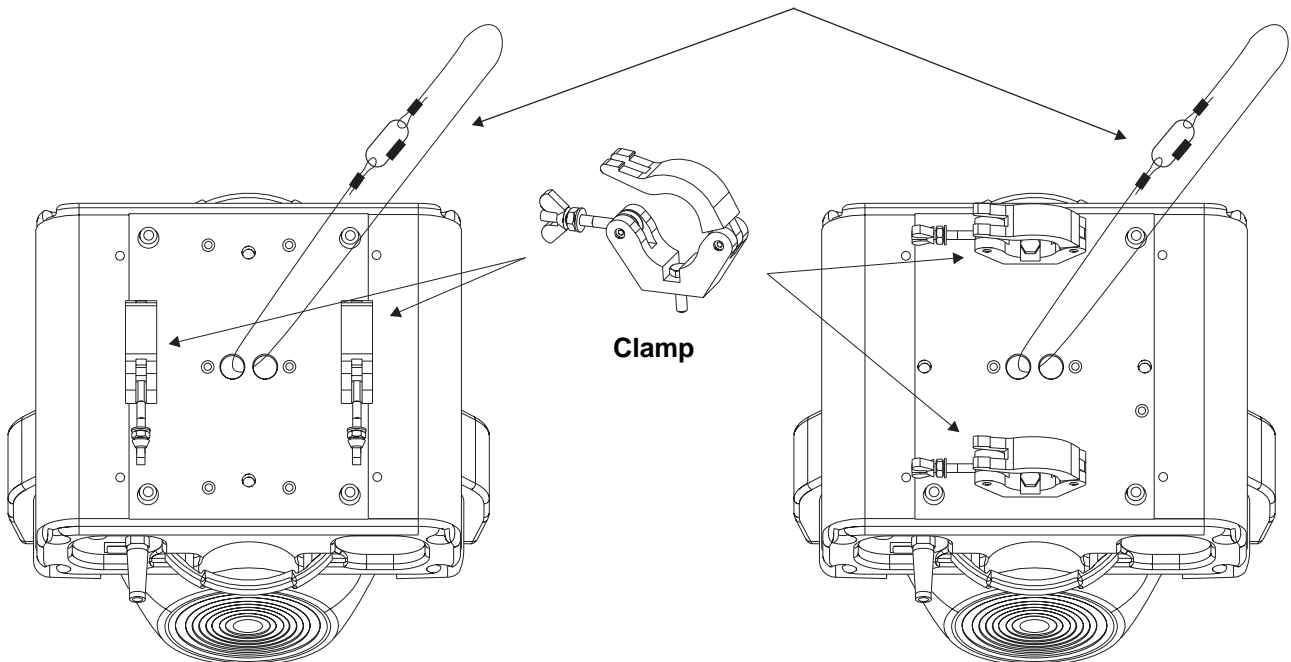

3.3 Connection to the mains

Connect the fixture to the mains with the enclosed power-plug.
The earth has to be connected!

The occupation of the connection-cables is as follows:

Cable	Pin	International
Brown	Live	L
Blue	Neutral	N
Yellow/Green	Earth	

3.4 DMX-512 connection/connection between fixtures

 **The wires must not come into contact with each other, otherwise the fixtures will not work at all, or will not work properly.** 

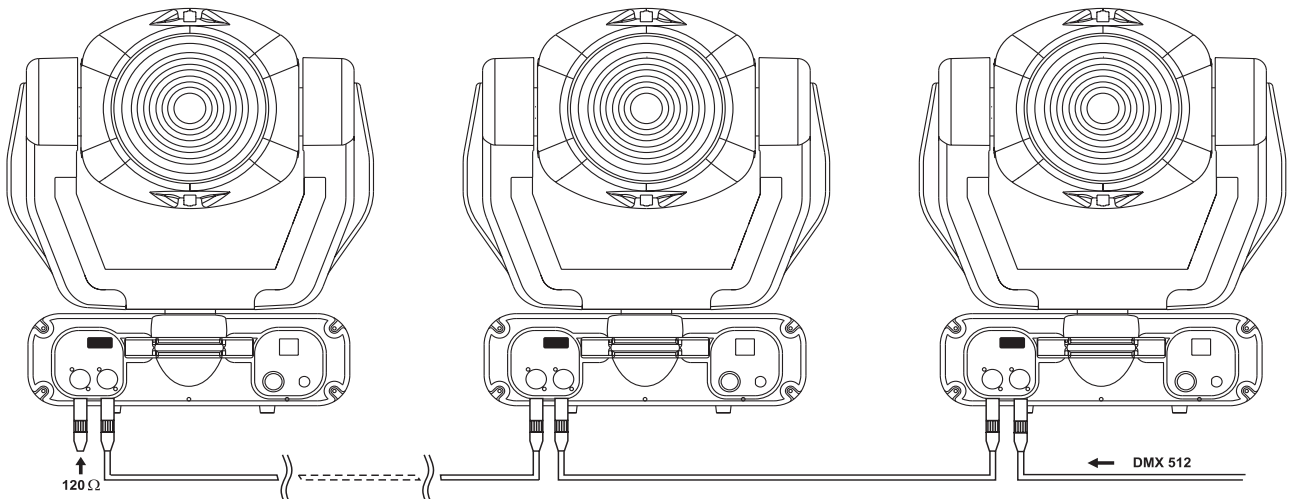

Only use a stereo shielded cable and 3-pin XLR-plugs and connectors in order to connect the controller with the fixture or one fixture with another.

Occupation of the XLR-connection:

DMX - output
XLR mounting-socket:

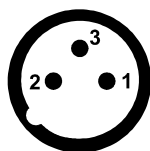

- 1 - Ground
- 2 - Signal (-)
- 3 - Signal (+)

DMX-input
XLR mounting-plug:

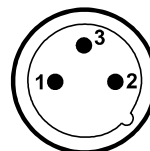

- 1 - Ground
- 2 - Signal (-)
- 3 - Signal (+)

If you are using the standard controllers, you can connect the DMX-output of the controller directly with the DMX-input of the first fixture in the DMX-chain. If you wish to connect DMX-controllers with other XLR-outputs, you need to use adapter-cables.

Building a serial DMX-chain:

Connect the DMX-output of the first fixture in the DMX-chain with the DMX-input of the next fixture. Always connect one output with the input of the next fixture until all fixtures are connected.

Caution: At the last fixture, the DMX-cable has to be terminated with a terminator. Solder a 120 W resistor between Signal (-) and Signal (+) into a 3-pin XLR-plug and plug it in the DMX-output of the last fixture.

4. DMX-Protocol

4.1 Function of the control channels - 16 bit protocol

4.1.1 Channel 1 - Pan

Push slider up in order to move head horizontally (PAN).
Gradual head adjustment from one end of the slider to the other (0-255, 128-center). The head can be turned by 530° and stopped at any position you wish.

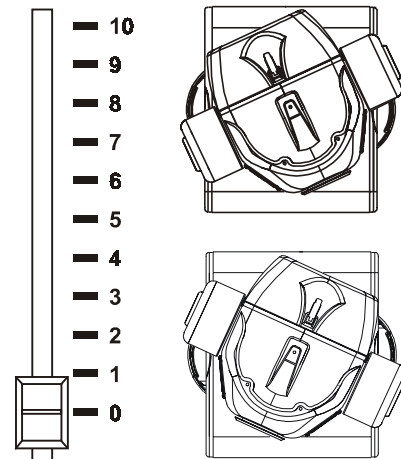

4.1.2 Channel 2 - Pan fine 16bit

4.1.3 Channel 3 - Tilt

Push slider up in order to move head vertically (TILT).
Gradual head adjustment from one end of the slider to the other (0-255, 128-center). The head can be turned by 280° and stopped at any position you wish.

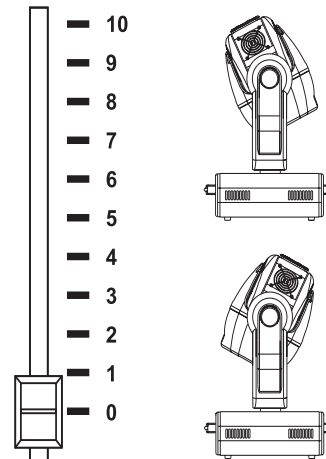

4.1.4 Channel 4 - Tilt fine 16bit

4.1.5 Channel 5 - Speed of PAN / TILT movement

0	Max speed (tracking mode)
1	Max speed (vector mode)
249	Min. speed (vector mode)
250-255	Max. speed, black-out while PAN, TILT moving or color changes (tracking mode)

4.1.6 Channel 6 - Switch On / Off the lamp, reset, speed control of cooling fan

0	open, max. speed of fan
127	open, min. speed of fan (silent operation) from 0 to 127 - decreasing speed of fan
128 - 139	Switch On the lamp, reset, open position
140 - 239	No function
230 - 239	Switch Off the lamp after 3sec.
240 - 255	No function

4.1.7 Channel 7 - Colour wheel

0 - 17	Open/white
18 - 35	Red
36 - 53	Blue
54 - 72	Green
73 - 90	CTF 3200 K
91 - 108	CTF 5600 K
109 - 127	UV filter
128 - 190	Forwards rainbow effect from fast to slow
191 - 192	No rotation
193 - 255	Backwards rainbow effect from slow to fast

4.1.8 Channel 8 - Cyan

0 - 255	Cyan (0 - white, 255 - full cyan)
---------	-----------------------------------

4.1.9 Channel 9 - Magenta

0 - 255	Magenta (0 - white, 255 - full magenta)
---------	---

4.1.10 Channel 10 - Yellow

0 - 255	Yellow (0 - white, 255 - full yellow)
---------	---------------------------------------

4.1.11 Channel 11 - Speed of CMY and Dimmer

0	Max speed
255	Min speed

4.1.12 Channel 12 - Colours macros - CMY and colour wheel

0 - 7	Off	128 - 135	Macro 16
8 - 15	Macro 1	136 - 143	Macro 17
16 - 23	Macro 2	144 - 151	Macro 18
24 - 31	Macro 3	152 - 159	Macro 19
32 - 39	Macro 4	160 - 167	Macro 20
40 - 47	Macro 5	168 - 175	Macro 21
48 - 55	Macro 6	176 - 183	Macro 22
56 - 63	Macro 7	184 - 191	Macro 23
64 - 71	Macro 8	192 - 199	Macro 24
72 - 79	Macro 9	200 - 207	Macro 25
80 - 87	Macro 10	208 - 215	Macro 26
88 - 95	Macro 11	216 - 223	Macro 27
96 - 103	Macro 12	224 - 231	Macro 28
104 - 111	Macro 13	232 - 239	Macro 29
112 - 119	Macro 14	240 - 247	Macro 30
120 - 127	Macro 15	248 - 255	Macro 31

4.1.13 Channel 13 - Effect wheel

0 - 70	Full beam
71 - 230	Beam shaper
231 - 255	Frost filter

4.1.14 Channel 14 - No function

4.1.15 Channel 15 - Shutter, Strobe

0 - 31	Shutter closed
32 - 63	No function (shutter open)
64 - 95	Strobe-effect from slow to fast (max. 10 flashes/second)
96 - 127	No function (shutter open)
128 - 159	Pulse-effect in sequences
160 - 191	No function (shutter open)
192 - 223	Random strobe-effect from slow to fast
224 - 255	No function (shutter open)

4.1.16 Channel 16 - Dimmer intensity

0 - 255	Intensity from 0 to 100 %
---------	---------------------------

4.2 Function of the control channels - 8 bit protocol

DMX Channel	1	2	3	4	5	6	7	8	9	10	11	12	13	14
Function	PAN	TILT	PAN/TILT SPEED	FAN ON/OFF LAMP	COLOURS	CYAN	MAGENTA	YELLOW	CMY SPEED	COLOURS MACROS	EFFECT	-	STROBO	DIMMER

5. Addressing

The control board on the front panel of the MOVITEC WL-250 allows you to assign the DMX fixture address, which is defined as the first channel from which the MOVITEC WL-250 will respond to the controller.

If you set, for example, the address to channel 5, the MOVITEC WL-250 will use the channel 5 to 20 for control. Please, be sure that you don't have any overlapping channels in order to control each MOVITEC WL-250 correctly and independently from any other fixture on the DMX data link.

If two, three or more MOVITEC WL-250 are addressed similarly, they will work similarly.

For address setting follow this procedure:

1. Switch On the MOVITEC WL-250 and wait until the fixture reset has finished ("rSt" is flashing at the display).
2. Press the **[Mode]** key in order to access the main menu. Browse through the menu by pressing the **[Up]** and **[Down]** keys until the display shows "A001". Confirm by pressing **[Enter]** key and the letter "A" will flash.
3. Use the **[Up]** and **[Down]** keys to select the desired address.
4. Confirm by pressing **[Enter]** or **[Mode]** to cancel.

Controlling:

After having addressed all MOVITEC WL-250, you may now start operating these via your lighting controller.

Note: After switching on, the WL-250 will automatically detect whether DMX 512 data is received or not.

If there is no data received at the DMX-input, the display will start to flash "A001" with actually set address.

This situation can occur if:

- the 3 PIN XLR plug (cable with DMX signal from controller) is not connected with the input of the WL-250
- the controller is switched off or defective, if the cable or connector is defective or the signal wires are swap in the input connector.

Note: It's necessary to insert the XLR termination plug (with 120 Ohm) in the last lighting in the link in order to ensure proper transmission on the DMX data link.

6. Remotely controllable functions

6.1 Lamp

The MOVITEC WL-250 is run with a MSD 250W/200W lamp.

A relay inside of the MOVITEC WL-250 allows you to switch On and Off the lamp via itself control board on the top side or via your controller without affecting the rest of the lighting.

6.2 Switching On and Off the lamp by Control Board

1. Switch On the MOVITEC WL-250 and wait until the fixture reset has finished.
2. Press the **[Mode]** key in order to access the main menu. Browse through the menu by pressing the **[Up]** and **[Down]** keys until the display shows "LAMP". Confirm by pressing **[Enter]** key.
3. Use the **[Up]** and **[Down]** keys to select "On" for switch On the lamp and "Off" for switch Off the lamp and press **[Enter]** to confirm or **[Mode]** to cancel.

Note: It is also important to note, that the discharge lamp is cold restrike types, that means, that they have to be cold before re-striking. For this reason, you have to wait 5 minutes (max. speed of fan must be adjusted) after having switched Off the lamp before you can switch it back On again. If you try to switch On the lamp within 5 minutes after having switched it Off, the MOVITEC WL-250 will store this information and automatically ignite the lamp when the 5 minutes period has expired. The message "HEAT" will appear on the control board display at the back side of the MOVITEC WL-250. If the ignition of the lamp is seven times unsuccessful, on the display will appear "LA.Er", meaning that the lamp could be damaged or even missed, or there could be a failure on the ignitor or ballast.

6.3 Colour wheel

The MOVITEC WL-250 features a colour-wheel with 7 color positions - 6 of these with dichroic colors and the last one open. It is also possible to rotate the color-wheel continuously at different speeds - the so-called "Rainbow effect" is created.

6.4 CMY - colours mixing system

The CMY color mixing system is based on graduated cyan, magenta, and yellow color filters. A continuous range of colors may be achieved by varying the amount of each filter from 0 to 100%.

6.5 Beam effects

The beam shaper allow you to widen and flatten beam. Beam shaper rotates 180°.

Frost filter on the same wheel as beam shaper softens the beam.

6.6 Dimmer

Smooth 0 - 100 % dimming is provided by the special dimmer unit.

6.7 Shutter/Strobe

Extremely fast shutter may also be used for strobe effect (1 - 10 flashes per second)

6.8 Fan

The MOVITEC WL-250 is cooled by free axial fans - two in the projector head and one in the base. The speed of the fan (and of course the noise) can be continuously reduced if very quiet performance is required.

By the Control Board using the „FAnS" function you can choose 4 types of low fan speed operating:

1. "High" - high (max) speed of fans

The cooling fans work on max. speed (max. cooling)

2. "reg" - continuous controlling of the fan speed

the fan automatically raises its speed in order to control inside temperature of the lighting, if the temperature inside increases about certain level (the low fan speed reduces the cooling of the lighting). This cycle can repeat several times until the temperature inside is on suitable level.

3. "loof" - low speed/Switch Off the lamp operating

the fan keeps the adjusted low speed until the temperature exceeds max. inside temp. then the MOVITEC WL-250 automatically switch Off the lamp.

4. "lohi" - low/high speed of the fan operating

the fan keeps the adjusted low speed until the temperature exceeds max. inside temp. of the fixture, then the MOVITEC WL-250 automatically switch from low to high the fan speed.

7. Control Board

The control board situated on the front panel of the MOVITEC WL-250 offers several features. You can simply set the lighting address, read the number of lamp or unit hours, switch On and Off the lamp, run test show, make a reset and also use special functions for manual, demo and service purposes.

The main menu is accessed by pressing the **[Mode]** key - press this one so many times until the display shows message "A001" (with actually stored address). Browse through the menu by the pressing **[Up]** and **[Down]** keys - the display shows step by step these messages: **A001, rPan, rTilt, 16br, Lati, Poti, LAMP, dEMo, rESE, SPEC**. Press **[Enter]** if you wish to select one of them. The functions provided are described in the following sections and the function hierarchy is shown below.

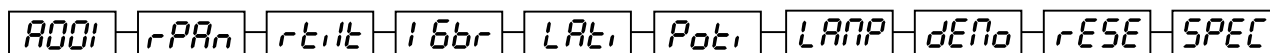

7.1 Main functions

A001 - DMX 512 Address settings

The letter "A" flashes. Use the **[Up]** and **[down]** keys to select required address (001 - 496) and press **[Enter]** to confirm or **[Mode]** to cancel and return to the main menu.

rPan - Pan reverse

This function allows you to invert the pan movement. Use the **[Up]** and **[Down]** keys to select "On" if you wish this feature or "Off" if you don't wish this feature and press **[Enter]** to confirm or **[Mode]** to cancel and return to the main menu.

rTilt - Tilt reverse

This function allows you to invert the tilt movement. Use the **[Up]** and **[Down]** keys to select "On" if you wish this feature or "Off" if you don't wish this feature and press **[Enter]** to confirm or **[Mode]** to cancel and return to the main menu.

16br - Movement resolution

By this function you can adjust the desired movement resolution 8 or 16 bit. Use the **[Up]** and **[Down]** keys to select 'On' if you wish the 16bit high resolution or "Off" if you wish only 8 bit resolution and press **[Enter]** to confirm or **[Mode]** to cancel and return to the main menu.

Note: If you adjust the 16 bit resolution the fixture will occupy 16 DMX channels, if you adjust the 8 bit resolution, the fixture will be operated by only 14 DMX channels. Please, check the DMX protocol.

LAti - Lamp On time

This option enables you to read the total number of hours that the lamp has been powered On. Press **[Enter]** or **[Mode]** to return to the main menu. In order to reset the counter to 0, you have to hold the **[Up]** and **[Down]**-button and press the **[Enter]**-button.

Poti - Power On time

By this option you can read the total number of hours that the MOVITEC WL-250 has been powered On. Press **[Enter]** or **[Mode]** to return to the main menu.

LAMP - Switch On/Off the lamp

Use the **[Up]** and **[Down]** keys to select "On" if you wish the switch On the lamp or "Off" if you wish switch Off the lamp and press **[Enter]** to confirm or **[Mode]** to cancel and return to the main menu.

dETo - Demo sequences

This function allows you to run a special demo-test sequences without an external controller, which will show you some possibilities of using WL-250. Press **[Up]** and **[Down]** keys to select the "Mod1" or "Mod2" sequences. The "Mod1" is suitable for projections on the wall, ceiling or ground without any head-movement, the "Mod2" uses all WL-250 functions and therefore is good for a complete introduction of the fixture.

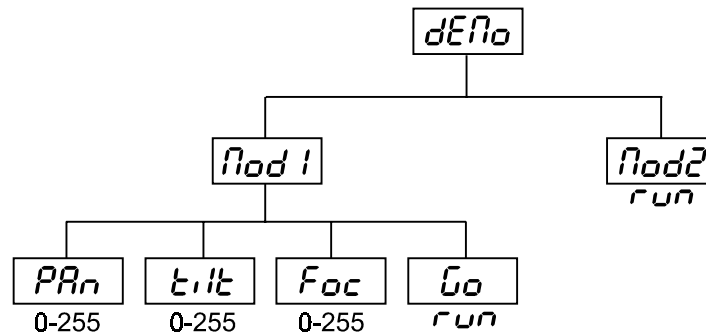

rESE - Reset Function

Press **[Enter]** key to run reset. This option enables the MOVITEC WL-250 to index all effects (functions) and return to their standard positions.

7.2 SPEC -Special functions

Use the **[Up]** and **[Down]** keys to browse through the special functions and select the one by pressing **[Enter]**.

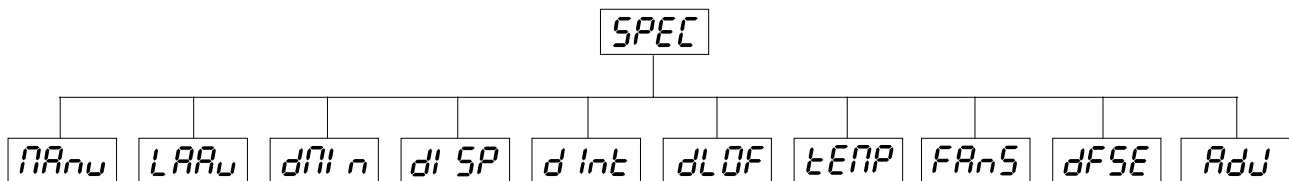

PRnu - Manual control of effects

This function allows you to control manually the channel functions of the fixture. Use the **[Up]** and **[Down]** keys to select desired function and press **[Enter]** to adjust the effect or **[Mode]** to cancel and return to the menu.

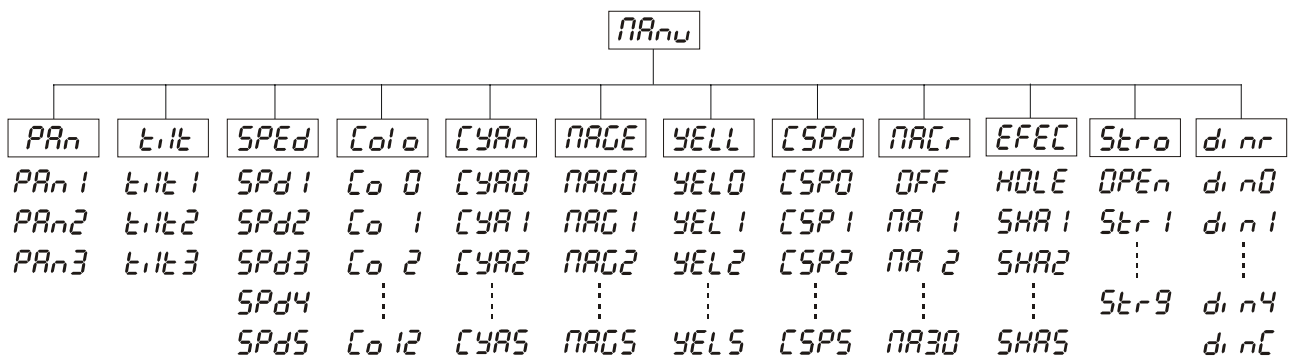

LARu - Lamp On automatically

This function enables to switch On the lamp automatically after switching On the fixture. Use the **[Up]** and **[Down]** keys to select "On" if you wish to switch On the lamp automatically after switching On the fixture or "Off" if you wish the camp off after switching On the fixture and press **[Enter]** to confirm or **[Mode]** to cancel and return to the menu.

dM n - DMX values

Readout DMX values of each channel received by the fixture. Use the **[Up]** and **[Down]** keys to select desired channel and press **[Enter]** to read its value coming to the fixture or **[Mode]** to cancel and return to the menu.

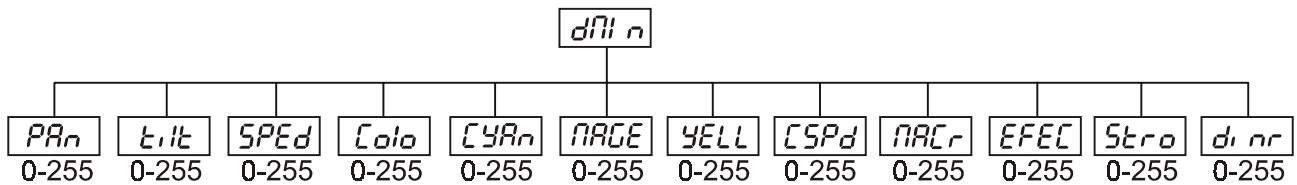

dI SP - Automatic blackout of Display

This function allows you to keep the display On or to turn Off automatically 2 minutes after last pressing any key on the control board. Use the **[Up]** and **[Down]** keys to select "On" if you wish to keep the display On or "Off" if you wish to turn Off automatically 2 minutes after last pressing any key on the control board and press **[Enter]** to confirm or **[Mode]** to cancel and return to the menu.

dInt - Display intensity

By this function you can adjust from 20% to 100% the intensity of the display. Use the **[Up]** and **[Down]** keys to select the level of the display intensity and press **[Enter]** to confirm or **[Mode]** to cancel and return to the menu.

dLOF - Lamp Off via DMX

This function allows you to switch Off the lamp by DMX. Use the **[Up]** and **[Down]** keys to select "On" if you want to switch Off the lamp by DMX or "Off" if you don't want to switch Off the lamp by DMX and press **[Enter]** to confirm or **[Mode]** to cancel and return to the menu.

tEMP - Temperature

Temperature readouts of fixture inside in Celsius. Inside temperatures below 70° C are not critical. 70° C and more lead to the lamp being switched off. Please note that the outside temperature should not exceed 45° C.

FANS - Low fan speed operating

By using this function you can choose 3 types of low fan speed operating. Browse through this menu by the pressing **[Up]** and **[Down]** keys - the display shows step by step these messages: "HIGH, reG, LoOF, LoHI,". Press **[Enter]** if you wish to select one of them or **[Mode]** to cancel and return to the menu.

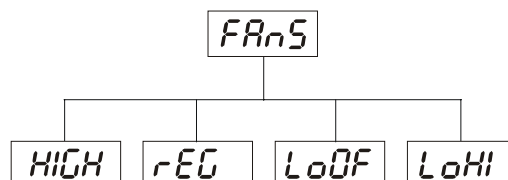

HI GH - high (max) speed of fans

The cooling fans work on max. speed (max. cooling)

reG - continuous controlling of the fan speed

the fan automatically raises its speed in order to control inside temperature of the lighting, if the temperature inside increases about certain level (the low fan speed reduces the cooling of the lighting). This cycle can repeat several times until the temperature inside is on suitable level.

LoOF - low speed/Switch Off the lamp operating

the fan keeps the adjusted low speed until the temperature exceeds max. inside temp.. then the MOVITEC WL-250 automatically switch Off the lamp.

LoHI - low/high speed of the fan operating

the fan keeps the adjusted low speed until the temperature exceeds max. inside temp..of the fixture, then the MOVITEC WL-250 automatically switch from low to high the fan speed.

dfSE - Default settings

Press **[Enter]** to reset all fixture personalities (not the adjusting functions) to the default values. On the display will appear "rSt" meaning that the fixture makes the reset. See the table of personality setting and their default positions.

Personality	Display	Default values (SHADED)
Pan reverse	rPAN	On
		OFF
Tilt reverse	rtilt	On
		OFF
Movement resolution	16br	On
		OFF
Lamp on automatically	LAAU	On
		OFF
Automatic blackout of display	di SP	On
		OFF
Display intensity	dInt	20 40 60 80 100
Lamp Off via DMX	dLOF	On
		OFF
Low fan speed operating	FANS	HIGH
		rEG
		LoDF
		LoHI

Adj - Adjusting the default positions of colour and CMY

By this function you can calibrate and adjust the colour and CMY to their standard/right positions. Use the **[Up]** and **[Down]** keys to browse through the adjusting menu - the display shows step by step these messages: "PAN, Tilt, SPed, Colo, CYAn, MAGE, YELL, MACr, EFEC, Stro, dimr, FCAL" by which you can adjust the fixture to the required/desired position (0-255) before the function calibration. Then when the positioning is finished use the last "FCAL" function (Fixture calibration).

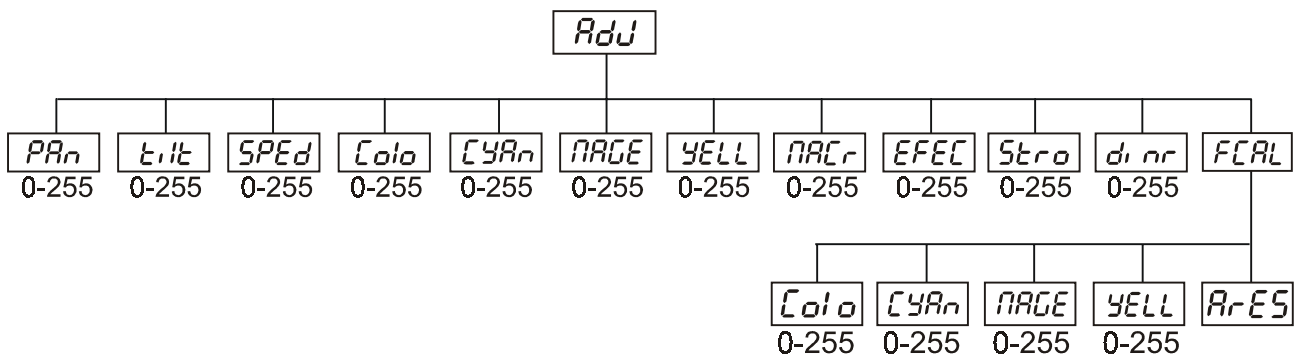

1. Calibration via the control board

Press **[Enter]** and the **[Up]** and **[Down]** keys in order to display the following messages: "Colo, CYAn, MAGE, YELL," for very smooth function calibration. Select one of them, press **[Enter]** and use the **[Up]** and **[Down]** keys in order to adjust their right value from 0 to 255. Then press **[Enter]** to confirm or **[Mode]** to cancel and return to the menu. This can be repeated for each calibration parameter if it is required. When the calibration is finished, it is necessary to use the "ArES" function in order to write the calibration values to the memory (EPROM) and to make a reset in order to check the newly adjusted positions of the colour and CMY wheels. When the reset of the fixture is finished, the display will show the "FCAL" message. Press **[Enter]** to repeat the calibration or **[Mode]** to return to the "Adj" menu.

2. Calibration via the external controller

Press **[Enter]** and the **[Up]** and **[Down]** keys in order to display the following messages: "**Colo, CYAn, MAGE, YELL**" - calibration parameters. Select one of them and press **[Enter]**.

Now you can calibrate the colour and CMY wheels by your controller. The DMX calibration protocol is described in the table mentioned below.

DMX Calibration protocol:

DMX Channel	1	2	3	4	5	6	7	8
Function	COL.	CYAN	MAGENTA	YELLOW	-	-	COLOURS	CYAN
	CALIBRATION 0 - 255		CALIBRATION 0 - 255	CALIBRATION 0 - 255	-	-	STANDARD PROTOCOL	STANDARD PROTOCOL
SMOOTH MICROSTEP MOVEMENT								

9	10	11	12	13	14	15	16
MAGENTA	YELLOW	SPEED CMY, DIMMER	COLOUR MACROS	BEAM EFFECTS	-	STROBO	DIMMER
STANDARD PROTOCOL	STANDARD PROTOCOL	STANDARD PROTOCOL	STANDARD PROTOCOL	STANDARD PROTOCOL	-	STANDARD PROTOCOL	STANDARD PROTOCOL

After having calibrated required functions press **[Enter]** to confirm (or **[Mode]** to cancel and return to the menu without reset by the "**ArES**" function) and use the "**ArES**" function in order to write the calibration values to the memory (EEPROM) and to make a reset in order to check the new adjusted positions of the colour and CMY wheels.

8. Error and information messages

HEAt

This message appears if you try to switch on the lamp within 5 minutes after having switched it off (the lamp is too hot). The message will appear on the display if the lamp doesn't ignite within 28 seconds. The MOVITEC WL-250 will store this information and automatically ignite the lamp when the 5 minutes period has expired.

LAEr

The ignition of the lamp is seven times unsuccessful (the HEAt message appeared six times before), and the display shows "**LAEr**", meaning that the lamp could be damaged or even missed, the fixture is overheating (this can occur if the ambient temperature is 45° C or more) or there could be a failure on the ignitor or ballast.

Please place or replace the lamp, check the ambient temperature or contact your dealer if the situation was not caused by the lamp.

AbEr

This message informs you that the main PCB does not communicate correctly with the Control Board.

CoEr

(color-wheel error) This message will appear after the reset of the fixture if the magnetic-indexing circuit malfunctions (sensor failed or magnet missing) or the stepping-motor is defective (or its driver circuit on the main PCB). The color-wheel is not located in the default position after the reset.

FtEr

This error message informs you that the fixture was overheating (occured if the ambient temperature is 45° C or more) and that the relay switched off the lamp. This message will appear on the display until the temperature will be on a suitable level, then the display will show the HEAt message meaning the lamp is too hot (explanation see above).

SnEr

This message appears if the lamp lighting sensor is failed. Please, contact your dealer.

PoEr

This message will appear if the fixture was shortly disconnect from the main.

PPEr

(PAN-yoke movement error) This message will appear after the reset of the fixture if the yoke's magnetic-indexing circuits malfunction (sensors failed or magnet missing) or the stepping motor is defective. (Or its driving IC on the main PCB). The yoke is not located in the default position after the reset.

TEr

(TILT-head movement error) This message will appear after the reset of the fixture if the head's magnetic-indexing circuit malfunctions (sensor failed or magnet missing) or the stepping motor is defective. (Or its driving IC on the main PCB). The head is not located in the default position after the reset.

FrEr

It will appear if the frequency of the main is not standard 50 or 60Hz.

9. Technical specifications

Power supply

EU-model: 210/230/250 V AC, 50/60 Hz ~
Fuse: T 3.15 A, 250 V
US-model: 100/115/208/230 V AC, 50/60 Hz ~
Fuse: T 6.3A,
Power consumption: 500 W

Lamp

MSD/HSD 230 V/250 W GY-9.5 or MSD/HSD 230 V/200 W GY-9.5

Colours

- CMY - colours mixing system
- 6 dichroic-filters plus white
- Colour-wheel with variable rotation speed

Beam effects

- Beam shaper
- Frost filter

Strobe

- Strobe effect with variable speed (1 - 10 flashes per second)

Dimmer

- Smooth dimmer from 0 - 100 %

Motor

- 9 high quality stepping-motors controlled by microprocessors

Electronics

- Digital serial input DMX-512
- 16 control-channels (full 16 bit protocol):
Channel 1: Horizontal mirror-movement 8 bit
Channel 2: Fine Horizontal mirror-movement 16 bit
Channel 3: Vertical mirror-movement 8 bit
Channel 4: Fine Vertical mirror-movement 16 bit
Channel 5: Pan/Tilt speed
Channel 6: Fan speed, On/Off lamp, reset
Channel 7: Colours wheel
Channel 8: Cyan
Channel 9: Magenta
Channel 10: Yellow
Channel 11: Speed of CMY and Dimmer
Channel 12: Colours macros - CMY and colour wheel
Channel 13: Beam effect
Channel 14: No function
Channel 15: Shutter, strobe
Channel 16: Dimmer

Pan/Tilt

Pan movement range 530°

Tilt movement range 280°

8/16 bit movement resolution

Automatic Pan / Tilt position correction

Maximum PAN-movement 530° in 2.65 s

Maximum TILT-movement 280° in 1.68 s

Rigging

Stands directly on the floor

Mounts horizontally or vertically with 2 clamps

2 truss orientation

Safety chain/cord attachment point

Temperatures

Maximum ambient temperature t_a : 45° C

Maximum housing temperature t_B (steady state): 80° C

Dimensions and weight

Length of base (including handles): 372 mm

Width of yoke: 426 mm

Height (head horizontal): 500 mm

Weight (net): 16 kg

Shipping weight: 25 kg

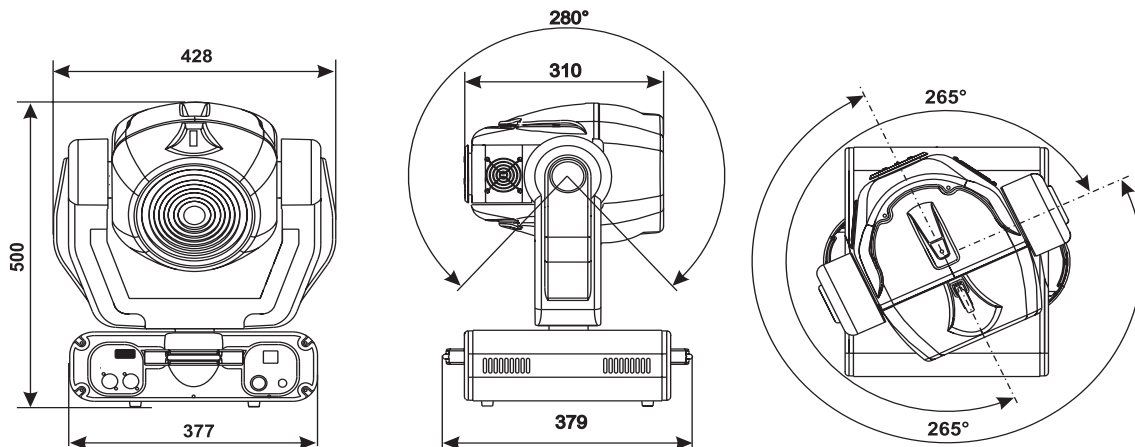

10. Maintenance and cleaning

It is absolutely essential that the fixture is kept clean and that dust, dirt and smoke-fluid residues must not build up on or within the fixture. Otherwise, the fixture's light-output will be significantly reduced. Regular cleaning will not only ensure the maximum light-output, but will also allow the fixture to function reliably throughout its life. A soft lint-free cloth moistened with any good glass cleaning fluid is recommended, under no circumstances should alcohol or solvents be used!

DANGER
HIGH
VOLTAGE

DANGER !
**Disconnect from the mains before starting any
maintenance work**

DANGER
HIGH
VOLTAGE

The fresnel lens will require weekly cleaning as smoke-fluid tends to building up residues, reducing the light-output very quickly. The cooling-fans should be cleaned monthly.

The interior of the fixture should be cleaned at least annually using a vacuum-cleaner or an air-jet. The dichroic colour-filters should be cleaned monthly.

Replacing the fuse

If the lamp burns out, the fine-wire fuse of the device might fuse, too. Only replace the fuse by a fuse of same type and rating (T 3.15 A, 250 V slow).

Before replacing the fuse, unplug mains lead.

Procedure:

Step 1: Unscrew the fuseholder on the rear panel with a fitting screwdriver from the housing (anti-clockwise).

Step 2: Remove the old fuse from the fuseholder.

Step 3: Install the new fuse in the fuseholder.

Step 4: Replace the fuseholder in the housing and fix it.

11. Appendix

We believe you will enjoy your MOVITEC WL-250. We assure you will enjoy this product for years if you follow the instructions given in this manual.

If you have any questions and comments, please do not hesitate to contact us.